

ProfiMaster - Art. No.:60 650 100

- » Robust quality
- » High capacity filter



Applications

- » Also suitable for high-alloy steel
- » Low to medium levels of smoke and dust
- » Occasional to frequent use

Benefits

- » Safe operation by rotation field control
- » Maintenance door allows easy filter change
- » Exhaust arm requires less adjustment due to exhaust hood design
- » Increased safety due to filter monitoring

Properties

- » Automatic Start/Stop (optional)
- » Exhaust arm up to 4 m
- » Rotating exhaust hood

Accessories

- » Automatic Start/Stop

Technical Data

Art. No	60 650 100
Filter	
Filter stages	2
Filter method	Disposable filter
Filter surface	ca. 17 m ²
Type of filter	Filter cassette
Filter material	Non-woven fibre
Filter efficiency	> 99.5 %
Filterclass	E12
Additional filters	Pre-filter
Basic data	
Extraction capacity	1,100 m ³ /h
Weight	95 kg
Motor power	1.1 kW
Power supply	3 x 400 V / 50 Hz
Rated current	2.3 A
Control voltage	24 V, DC
Noise level	70 dB(A)

Additional information	
IFA-Certification	W3-Approved
Fan type	Radial fan
Quantity of extraction arms	1
Exhaust arm type	flexible exhaust arm
Diameter extraction arm	150 mm
Length of exhaust arm	2 m

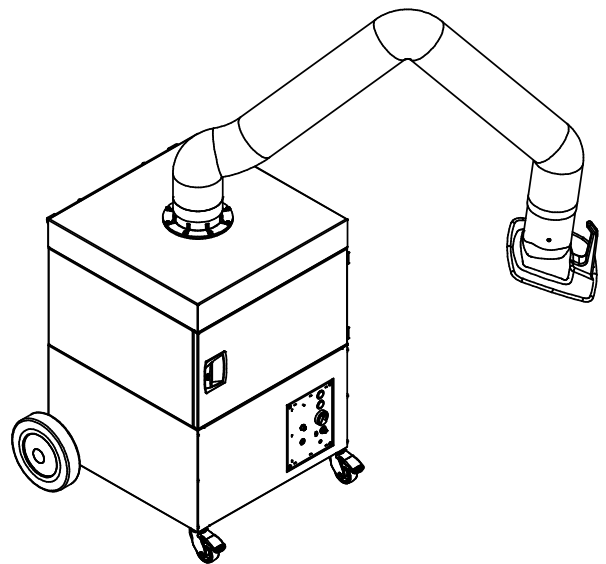
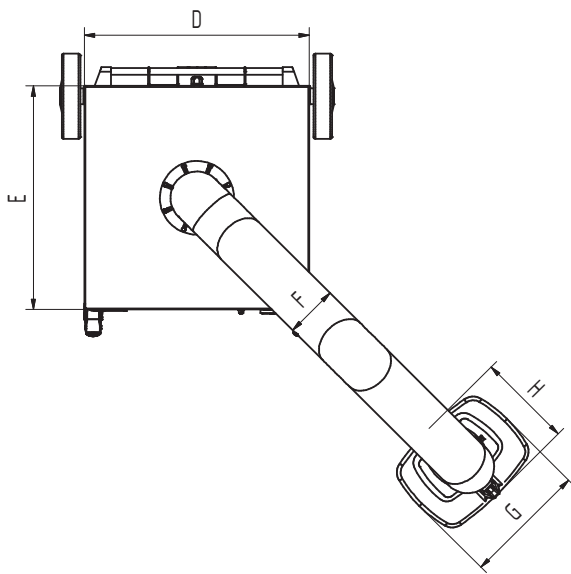
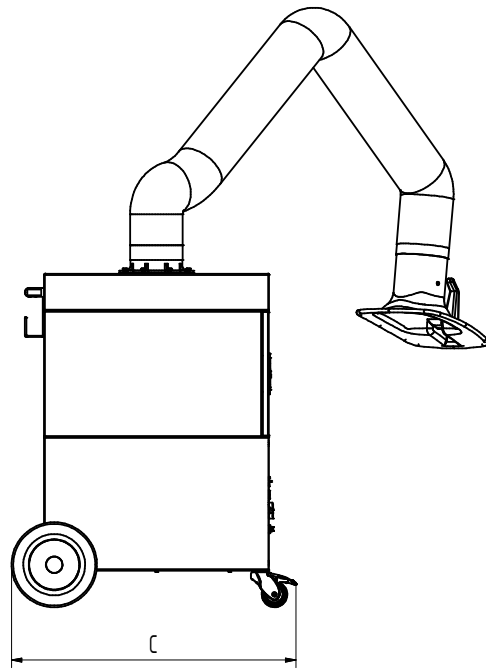
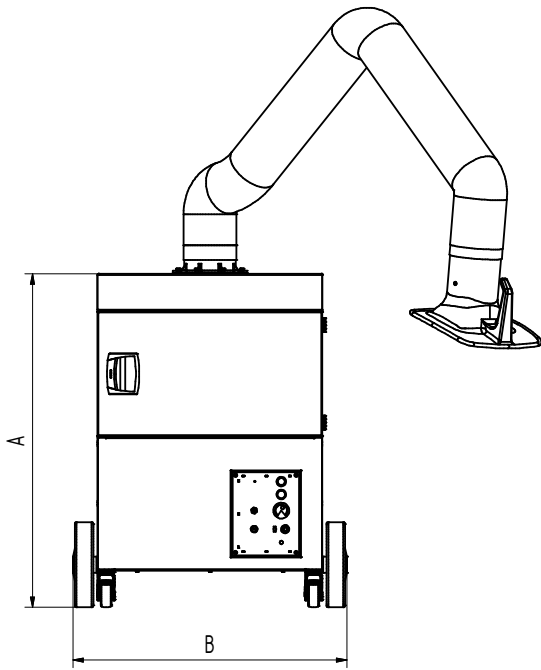

Technical Data

Dimensions

A	977 mm
B	797 mm
C	828 mm
D	655 mm
E	655 mm
F	150 mm
G	360 mm
H	295 mm